



## FINAL SEMESTER EXAMINATION

**Student NRIC** : \_\_\_\_\_  
**Student ID** : \_\_\_\_\_

Programme	:	<b>DIPLOMA IN COMPUTER SCIENCE (MQA/PA13808)</b>
Intake	:	<b>JAN 2021 (YEAR 1 SEMESTER 3)</b>
		<b>MAY / JUN 2021 (YEAR 1 SEMESTER 2)</b>
Course	:	<b>INTRODUCTION TO COMPUTER ARCHITECTURE</b>
Course Code	:	<b>DCS1213</b>
Duration	:	<b>3 HOURS</b>

### INSTRUCTIONS TO CANDIDATES:

1. Please read the instructions given in the question paper **CAREFULLY**.
2. The question paper consists of **FOUR (4)** questions.
3. Answer **ALL** questions in the question paper.
4. Answers to the questions are to be written into the examination booklet.
5. Electronic dictionaries, lecture notes, files or any unauthorised materials except writing equipment are strictly prohibited.

This question paper must be submitted along with all used and/or unused rough papers and/ or graph papers (if any). Candidates are **NOT ALLOWED** to take any examination paper(s) used or unused out of the examination hall.

### WARNING:

The Examination Board of Peninsula College Georgetown regards cheating as a very serious offence and will not hesitate to mete out the appropriate punitive actions according to the severity of the offence committed, and in the accordance with the clauses stipulated in the Students' Handbook, up to and including expulsion from Peninsula College Georgetown.

*(This booklet contains 4 printed pages including this page)*

**DO NOT OPEN THIS BOOKLET UNTIL YOU ARE ALLOWED TO DO SO**

For examiner's use only

QUESTION NO.	MARKS
1	/ 25
2	/ 25
3	/ 25
4	/ 25
<b>Total</b>	<b>/ 100</b>

Answer **ALL** questions on the separate sheet provided.

**[100 marks]**

1. a) Define the following terms.

- i) Computer Architecture (2 marks)
- ii) Computer Organisation (2 marks)
- iii) Integrated Circuit (2 marks)

b) Calculate the expression below. Write the answer in a hexadecimal system.

$$1100\ 1001_2 - 1111_2$$

(9 marks)

c) Based on the following logic circuit, answer the questions below.

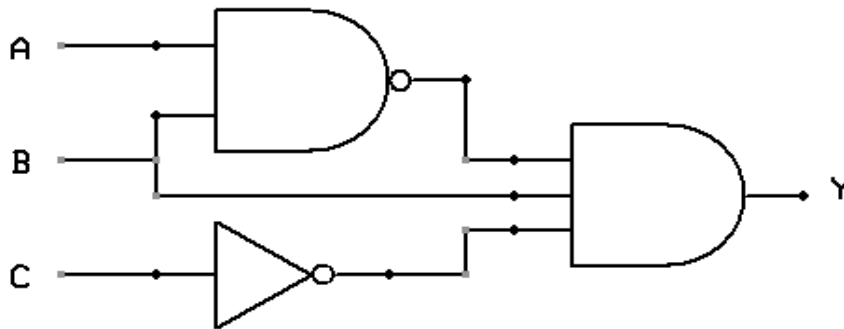

- i) Build a truth table. (7 marks)
- ii) Write a Boolean expression. (3 marks)

Total: [25 marks]

2. a) Compare and contrast primary memory and secondary memory with an example for each. (8 marks)

b) Briefly discuss how the paging works on the RAM with the help of a diagram. (6 marks)

c) Perform a Least Recently Used (LRU) cache algorithm for analysing the usage of the cache below. (7 marks)

Time	1	2	3	4	5	6	7	8	9	10	11	12	13	14	15
Pages	A	B	C	A	D	A	E	C	D	A	D	E	D	C	E

d) Determine the following devices as INPUT or OUTPUT devices.

i) Computed Tomograph Scan (CT Scan) (1 mark)

ii) Plotter (1 mark)

iii) Speech Generating Device (SGD) (1 mark)

iv) Laser Rangefinder (1 mark)

Total: [25 marks]

3. a) Elaborate on how the following I/O handlings work.
- i) Polling (3 marks)
  - ii) Interrupt (2 marks)
- b) Ergonomics is concerned with how to arrange devices in a way that make people more comfortable and efficient in their work. It also looks at how people interact with the input and output devices to minimise the amount of physical strain placed on their bodies. Recommend **FOUR (4)** suggestions to users when they want to reduce strain on the body. (8 marks)
- c) Distinguish **FOUR (4)** differences between Complex Instruction Set Computing (CISC) and Reduced Instruction Set Computing (RISC). (8 marks)
- d) Justify why parallel computing is a solution to solve a respective problem. (4 marks)
- Total: [25 marks]
4. a) Describe how the assembly instructions below work.
- i) LDI R17, \$10 (3 marks)
  - ii) SUB R16, R17 (3 marks)
  - iii) ADD R16, R17 (3 marks)
- b) Assume a computer load value of 27 into register 16 before running assembly instructions in **Question 4 (a)**, answer the following questions.
- i) Code an assembly instruction with a \$ sign. (3 marks)
  - ii) Get the value (base 10) in register 16 after subtraction. (3 marks)
  - iii) Find hexadecimal numbers in registers 16 and 17 after addition. (4 marks)
- c) Differentiate **THREE (3)** types of translators in computing. (6 marks)
- Total: [25 marks]

**- END OF QUESTIONS -**